

**1. PREAMBLE:**

The significance of the Electrical Measurements Lab is renowned in the various fields of engineering applications. For an Electrical Engineer, it is obligatory to have the practical ideas about the Electrical Measurements. By this perspective we have introduced a Laboratory manual cum Observation for Electrical Measurements Lab.

The manual uses the plain, cogent and simple language to explain the fundamental aspects of Electrical measurements in practical. The manual prepared very carefully with our level best. It gives all the steps in executing an experiment.

## 2. OBJECTIVE & RELEVANCE

The main objectives of this lab course are

- i) To expose the students to different types of electrical measuring instruments.
- ii) To make the students understand how to use these instruments for measuring an unknown quantity.
- iii) To calibrate & test different types of electrical measuring instruments.

### Outcome

Now a days Electrical Energy plays in important role in our day to day life. In our power system the load changes are very imminent, so according to load the quantity of power supply should change for time to time. Electrical measurements deals with the measurement of stability and working standards of the meter, this includes the knowledge of utilization and control of electrical energy. So it is important to know the basic knowledge about Electrical engineering.

### 3. List of Experiments:

- 1 Calibration And Testing Of Single Phase Energy Meter
- 2 Calibration Of Dynamometer Type Power Factor Meter
- 3 Crompton D.C. Potentiometer – Calibration of PMMC ammeter and PMMC voltmeter
- 4 Kelvin's Double bridge-Measurement of resistance – Determination of Tolerance
- 5 SILSBEE'S METHOD OF THE TESTING CURRENT TRANSFORMERS
- 6 Schering bridge & Anderson bridge.
- 7 Measurement of 3 Phase reactive power with single – phase wattmeter
- 8 Measurement of parameters of a choke coil using 3 voltmeter and 3 ammeter methods
- 9 Calibration LPF wattmeter – by Phantom testing
- 10 Measurement of 3 phase power with single watt meter and 2 No's of C.T.
- 11 Measurement of 3-phase Reactive Power using two wattmeters.
- 12 LVDT AND CAPACITANCE PICKUP-CHARACTERISTICS AND CALIBRATION
- 13 MEASUREMENT OF IRON LOSS IN A BAR SPECIMEN USING A CRO AND USING A WATTMETER

#### 4 . Text and Reference Books

1. Electrical Measurements and measuring Instruments – E.W. Golding and F.C. Widdis, 5<sup>th</sup> edition, Wheeler Publishing.
2. Electrical & Electronic Measurement & Instruments – A.K. Shawney Dhanpat Rai & Sons Publications.
3. Electrical Measurements – Buckingham and Price, Prentice – Hall.
4. Electrical Measurements – Harris.
5. Electrical Measurements: Fundamentals, Concepts, Applications – Reissland, M.U. New Age International (P) Limited, Publishers.

**5. SESSION PLAN**

Sl.No	Name of the Experiment	Week of Experiment
1	Calibration And Testing Of Single Phase Energy Meter	Week #1
2	Calibration Of Dynamometer Type Power Factor Meter	Week #2
3	Crompton D.C. Potentiometer – Calibration of PMMC ammeter and PMMC voltmeter	Week #3
4	Kelvin's Double bridge-Measurement of resistance – Determination of Tolerance	Week #4
5	SILSBEE'S METHOD OF THE TESTING CURRENT TRANSFORMERS	Week #5
6	Schering bridge & Anderson bridge.	Week #6
7	Measurement of 3 Phase reactive power with single – phase wattmeter	Week #7
8	Measurement of parameters of a choke coil using 3 voltmeter and 3 ammeter methods	Week #8
9	Calibration LPF wattmeter – by Phantom testing	Week #9
10	Measurement of 3 phase power with single watt meter and 2 No's of C.T.	Week #10
11	Measurement of 3-phase Reactive Power using two wattmeters.	<u>Week #11</u>
12	LVDT AND CAPACITANCE PICKUP-CHARACTERISTICS AND CALIBRATION	<u>Week #12</u>
13	MEASUREMENT OF IRON LOSS IN A BAR SPECIMEN USING A CRO AND USING A WATTMETER	<u>Week #13</u>

## 6. Experiment write up:

### 6.1. CALIBRATION AND TESTING OF SINGLE PHASE ENERGY METER

**AIM :** To calibrate the given energy meter using a calibrated wattmeter.

**APPARATUS :**

1. Variac, single phase, 10A
2. Voltmeter, 300 V AC
3. Ammeter, 0-10A, AC
4. Rheostat, - Lamp load
5. Wattmeter, LPF, 300 V, 10 A
6. Single phase energy meter

**THEORY :**

The calibration of energy meter may become inaccurate during its vigorous use due to various reasons. It is necessary to calibrate the meter to determine the amount of error i.e. its reading so that same meter can be used for correct measurement of energy.

In this method precision grade indicating instruments are used as reference standard. These indicating instruments are connected in the circuit of meter under test. The current and voltages are held constant during the test. The numbers of revolutions made by the test are recorded. The time taken is also measured.

Energy recorded by meter under test =  $R_x / K_x - \text{kWh}$ .

Energy computed from the readings of the indication instrument =  $\text{kW} \times t$

Where  $R_x$  = number of revolutions made by disc of meter under test.

$K_x$  = number of revolutions per kWh for meter under test.

$\text{KW}$  = Power in kilowatt as computed from readings watt meter indicating instruments  $t$  = time in hours.

$$\text{Percentage Error} = \frac{(R_x / K_x - \text{kW} \times t)}{\text{kW} \times t} \times 100$$

Before conducting any of these tests on a watt-meter its potential circuit must be connected to the supply for one hour in order to enable the self-heating of the potential coil to stabilize.

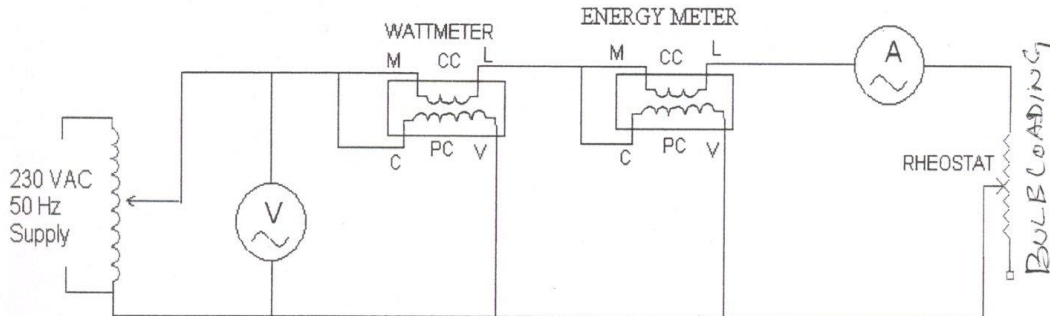
**CIRCUIT DIAGRAM:****Procedure :**

- Keep the Autotransformer at zero position.
- Make connections as per the circuit diagram shown below
- Switch on the 230 VAC, 50 Hz, power supply.
- Increase the input voltage gradually by rotating the Autotransformer in clockwise direction.
- Adjust the load rheostat so that sufficient current flows in the circuit. Please note that the current should be less than 4A.
- Note down the Voltmeter, Wattmeter and power factor meter readings for different voltages as per the tabular column.
- Note down the time (by using stop watch) for rotating the disc of the Energy Meter for 10 times.
- Find out the percentage error by using above equations.

**Table Column :**

S.no.	Voltage (V)	Current (I)	R=No of revolutions of the disc	Time (t) in hours	Energy meter reading in KWh=No. revolution <sup>o</sup> /meter constant (K)	Wattmeter Reading in kW X t	% Error

**CALCULATION:****RESULT:**



## 6.2. CALIBRATION OF DYNAMOMETER TYPE POWER FACTOR METER

**AIM :** To calibrate a given single phase power factor meter.

**Apparatus :**

1. Variac, single phase, 10A
2. Voltmeter, 300V AC
3. Ammeter, 0-10A, AC
4. Rheostat
5. Wattmeter, LPF, 300V, 10A
6. Dynamometer type power factor meter

**Theory :**

The error made by the Power factor meter can be calculated by noting down the readings of various meters and error can be calculated by using formula

Actual reading = Power factor meter reading

Theoretical reading  $\cos \phi = P / VI$

Single percentage of error =  $\frac{\text{Actual reading} - \text{T reading}}{\text{Theoretical reading}} \times 100$

**Circuit Diagram :**

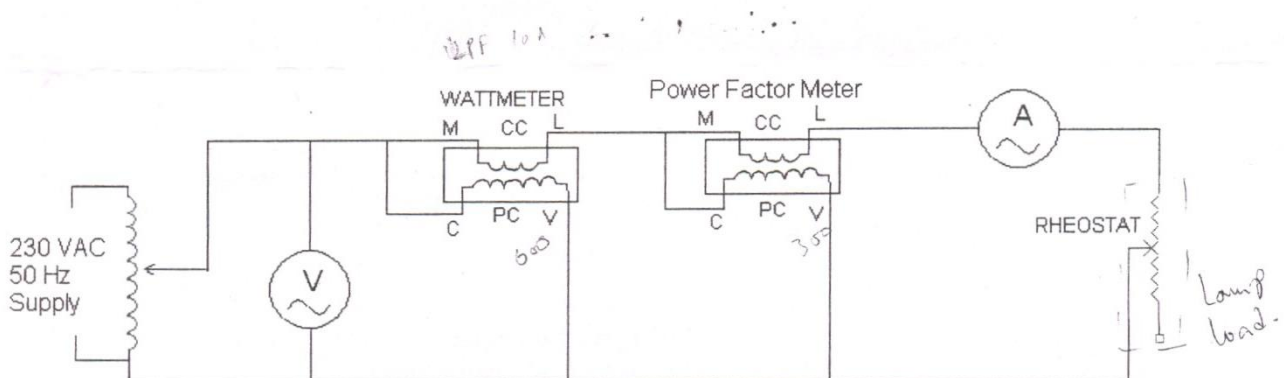

**Procedure :**

- Keep the Auto transformer at Zero position
- Make connections as per Circuit diagram shown below.
- Switch on the 230 VAC, 50 Hz, Power supply.
- Increase the input voltage gradually by rotating the auto transformer in clockwise direction 220V.
- Adjust the load rheostat so that sufficient current flows in the circuit, Please note that the current should be less than 4A.
- Note down the Voltmeter, Ammeter, Wattmeter and power factor meter readings for different voltage as per the tabular column.
- Find out the percentage error by using above equations.

**Tabular Column :**

S.no.	V AC	I AC	Wattmeter reading	Power Factor meter Reading	% Error

**CALCULATION:****RESULT:**

### **6.3 Crompton DC Potentiometer**

**Aim :** To calibrate the D.C. crompton's Potentiometer by calibration of voltmeter & ammeter method.

**Apparatus:**

Crompton's D.C. potentiometer circuit

**Theory :**

**Standardization of crompton D.C. potentiometer:**

A practical form of D.C. potentiometer which is very widely used in crompton potentiometer.

A standard westen cell is connected across terminals are standardization circuit the battery whose e.m.f. is to be measured is connected across terminals  $E_1$  &  $E_2$  with regard to polarity. T

He sliding contact  $E_2$  is set & the key 'K' is closed & null deflection is obtained by adjusting resistances course & fine Rheostats. The change over switch position, if the battery whose positions is to be measured to get balanced or null deflection.

**Calibration of Voltmeter:**

Voltmeter can be calibrated using DC potentiometer, any desired voltage with in the range of the voltmeter to be calibrated can be obtained using the potential divider. This voltage is applied of the I/P terminal of Volt ratio box. The voltmeter to be calibrated is connected across these terminals. The output voltage of the V.R. box is measured accuratrely with a d.c. potentiometer.

Theoretical value = (value voltage knob + value of mr knob) x (m.f at V.R. box)

Actual value = set value

% E =  $(AV - TV / (TV) \times 100$

Unknown potential = (main dial volts) + (slide wire dial volts x 0.001)

**Circuit Diagram:**

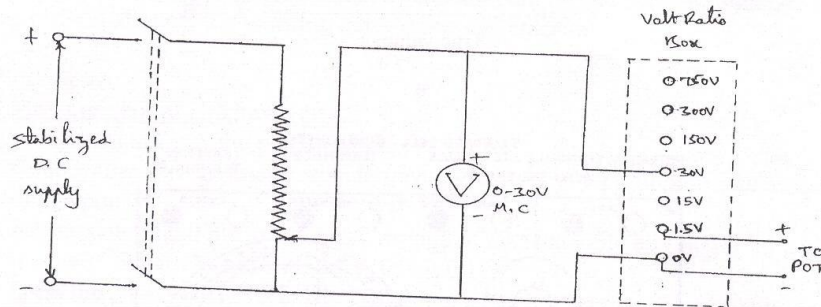
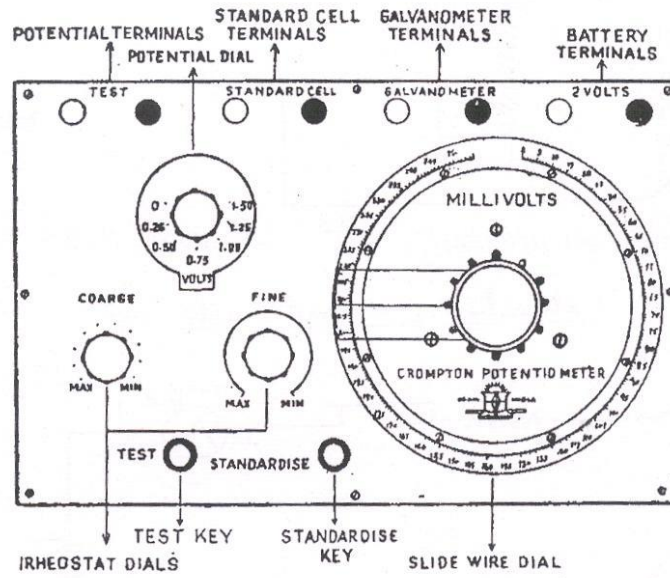

*Calibration of voltmeter with pot.*

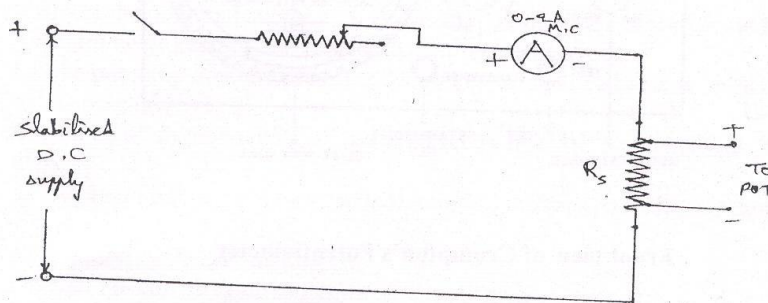

*Calibration of Ammeter with pot*

**Procedure:****Standard of crompton D.C. potentiometer**

1. D.C. potentiometer are used to calibrate voltmeter & ammeter.
2. A 2VDC supply is given to D.C. potentiometer
3. This can be achieved by standardised the giving D.C. potentiometer with the help of standard cell.
4. The connections are made as per the circuit diagram (A) placing shunt key at standard mode.
5. By adjusting course and time rheostat we observe the zero deflection in galvanometer

If galvanometer shows zero deflection we can conclude that D.C. potentiometer is standardised.

**Calibration of Voltmeter:**

1. Connect the circuit as per the circuit diagram.
2. Keep the function key on mode either E1 to E2
3. Set the voltage level so as to calibrate with crompton D.C. potentiometer.
4. By adjusting voltage knob & millivolts knob for zero deflection in the galvanometer.
5. Note down the readings by observing the p as of both knobs
6. Calculate theoretical value by considering multiplication factor from the voltratio box.
7.  $\% \text{ Error} = (\text{Actual value} - \text{Theoretical value}) / (\text{Theoretical value}) \times 100$

Theoretical value = (Value at voltage at knob + value at mv knob) x (m.f. at V-r knob)

Actual value = set value.

**Calibration of Voltmeter :**

Voltmeter reading $V_M$	True voltage measured by Pot, $V_T$	% Error = $(V_M - V_T) / V_T \times 100$

**Calibration of ammeter :**

Ammeter reading $I_M$	True current measured by Pot, $I_T$	% Error = $(I_M - I_T) / I_T \times 100$

**CALCULATION:****RESULT:**

### **6.4. KELVINS DOUBLE BRIDGE**

**AIM :** To determine the resistance using Kelvins double bridge.

**Apparatus :**

**Main dial :** 100 divisions of side wire are equal to 0.1 Ohms. Each main division is equal to 0.001 ohm. Each sub – division is equal to 0.0005 ohm. The readings to the left of zero is to be subtracted from the main dial readings & that of the right of zero is to be added to main dial reading.

**Range switch :** arrange multiplier witch furnishes 5 ranges of X 100, X 10, XZI & X 0.001. The value of unknown resistance is given by sum of main dial & slide wire reading multiplied by range used.

**Theory :**

The kelvins bridge is a modification of the wheat stone bridge & provides greatly increased accuracy in measurement of low resistances.

Kelvins Bridge is show in the figure where 'r' represents resistance of the lead that connects the unknown resistances 'R' to standard resistance 's' Tow galvanometer connections may ne either to point 'm' or point 'm' the resistance 'r' of the connecting leads is added to standard resistance resulting in indication of too low an indication of unknown resistance R. When the connection is made to pint 'n' the resistance r, is added to unknown resistance resulting in indication of too high a value of 'R'.

**CIRCUIT DIAGRAM:**

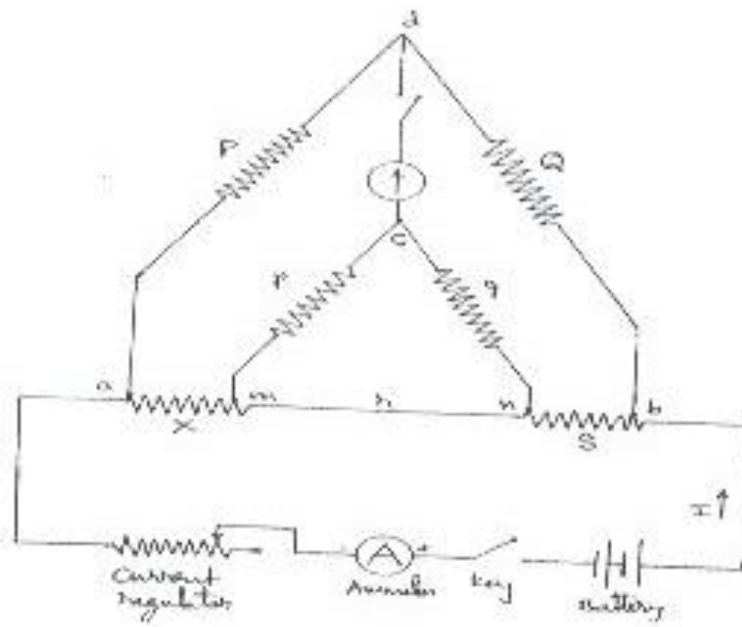

Circuit Diagram

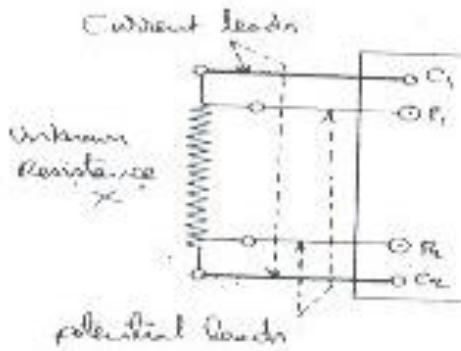

Connection of 4-Terminal Resistance

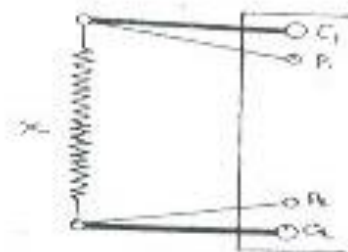

Connection of 2-Terminal Resistance



**Procedure :****Measurement of Resistance:**

1. Set the zero of the built in galvanometer in the FREE position and set the pointer in the centre. When external more sensitive galvanometer such as our spot light reflecting galvanometer is to be used,. It should be connected to the terminals marked "Ext. GALVO" the switch is set in the EXT. G positions accordingly. A galvanometer sensitivity control switch is provided to increase the galvanometer sensitivity gradually as null point approaches.
2. On the left-side of bridge there are 2 current terminal marked C & -C & 2 potential terminals marked + p& -P. Four leads are provided, one pair is called current lead. The second pair is called potential lead. Resistance of each potential lead is 10 milli ohms.
3. If The resistance to be measure is in the form of 2-terminals resistance the leads from -C & P are connected to one terminal & those from - & P are connected to the other terminal of unknown resistance. If the resistance to be measured is in the form of 4 terminal resistance then leads from -C -- -C -P should be connected to respective terminals of the unknown resistance taking proper care for polarity.
4. If the resistance is in the form of wire or ca coil connect one end of the wire to -C & the other end to -C & connect +C to +P & -C to -P with the help of leads provided. The resistance of wire b/w +C & -C will be measured.
5. When the unknown resistance has been suitable connected, choose the suitable range multiplier depending upon the magnitude of the unknown resistance.
6. The zero of the slide wire should be checked OFF & ON. For doing so, the leads from +C P - C & -P are shorted together. The null point should be obtained if the main dial & slide wire both reading zero.

Connect the main leads to 220v AC mains.

**CALCULATION:****RESULT:**

### 6.5. SILSBEE'S METHOD OF THE TESTING CURRENT TRANSFORMERS

**AIM;** To determine the percentage ration error and the phase angle of the given current transformer by comparison with another current transformer whose error are known.

#### **Apparatus :**

Standard CT (one for which the error are known)

Testing CT

Wattmeter, LPF – 2 Nos

Ammeter (MI type) 2-Nos

Rheostat

Phase shifting transformer

#### **Theory :**

This is a comparison type of test employing defect ional methods. Here the ratio and phase angle of the test transformer X are determined in terms of that of a standard transformer shaving same nominal ration.

The errors are as follows says:

Error	Ratio Error	Phase Angle Error
CT		
S	$R_s =$	$\theta_s =$
X	$R_x =$	$\theta_x =$

The primaries of the two CTs are connected in series and the current through them is say IP. The pressure coils of two watt meters are supplied with constant voltage V from a phase shifting transformer.

The current coil of wattmeter W1 is connected to S through an ammeter. The current coil of wattmeter W2 is connected as shown in fig and carries a current SI.

$$SI - I_{SS} - I_{SX} \text{ (Victorian difference)}$$

Where the current is in the current coil of W1 and  $I_{SX}$  is the current flowing through the

burden. The phase shifting transformer is adjusted so that the wattmeter W1 reads zero.

$$W_{1q} = V_{peq} I_{ss} \cos 90^\circ = 0$$

$$W_{1q} = V_{peq} I_{sx} \cos (\theta_x - \theta_s)$$

$$= V_{peq} I_{sx} \sin (\theta_x - \theta_s)$$

Where  $V_{peq}$  is the voltage from the phase shifting transformer, which is in quadrature with the  $I_{ss}$  in its current coil of W1.

Then the phase of the voltage from the phase shifting transformer is shifted through  $90^\circ$

Therefore, now  $V$  is phase with the current  $I_{ss}$ .

$$W_{1p} = V I_{ss}$$

$$W_{2p} = V I_{sx} \sin (\theta_x - \theta_s)$$

$$= V (I_{ss} - I_{sx} \cos (\theta_x - \theta_s))$$

$$= W_{1p} - V I_{sx} \cos (\theta_x - \theta_s)$$

$$\text{As } (\theta_x - \theta_s) \sim 0$$

$$\text{Therefore } V I_{sx} = W_{1p} - W_{2p}$$

$$R_x = I_p / I_{sx}$$

$$R_s = I_p / I_{sx}$$

$$\frac{R_x}{R_s} = \frac{I_{ss}}{I_{sx}} = \frac{V I_{ss}}{V I_{sx}} = \frac{W_{1p}}{W_{1p} - W_{2p}}$$

$$\text{Ratio error } R_x = R_s \left[ 1 + \frac{W_{2p}}{W_{1p}} \right]$$

Now to obtain the phase Angle Errors

$$\sin (\theta_x - \theta_s) = W_{2q} / V I_{sx}$$

$$\cos (\theta_x - \theta_s) = (W_{1p} - W_{2p}) / V I_{sx}$$

$$\tan (\theta_x - \theta_s) = W_{2q} / (W_{1p} - W_{2p})$$

OR

$$\text{Phase angle error } \theta_x = W_{2q} / (W_{1p} - W_{2p})$$

$$\text{Phase angle error } \theta_x = W_{2q} / (W_{1p} - W_{2p}) + \theta_s$$

**Circuit Diagram:**

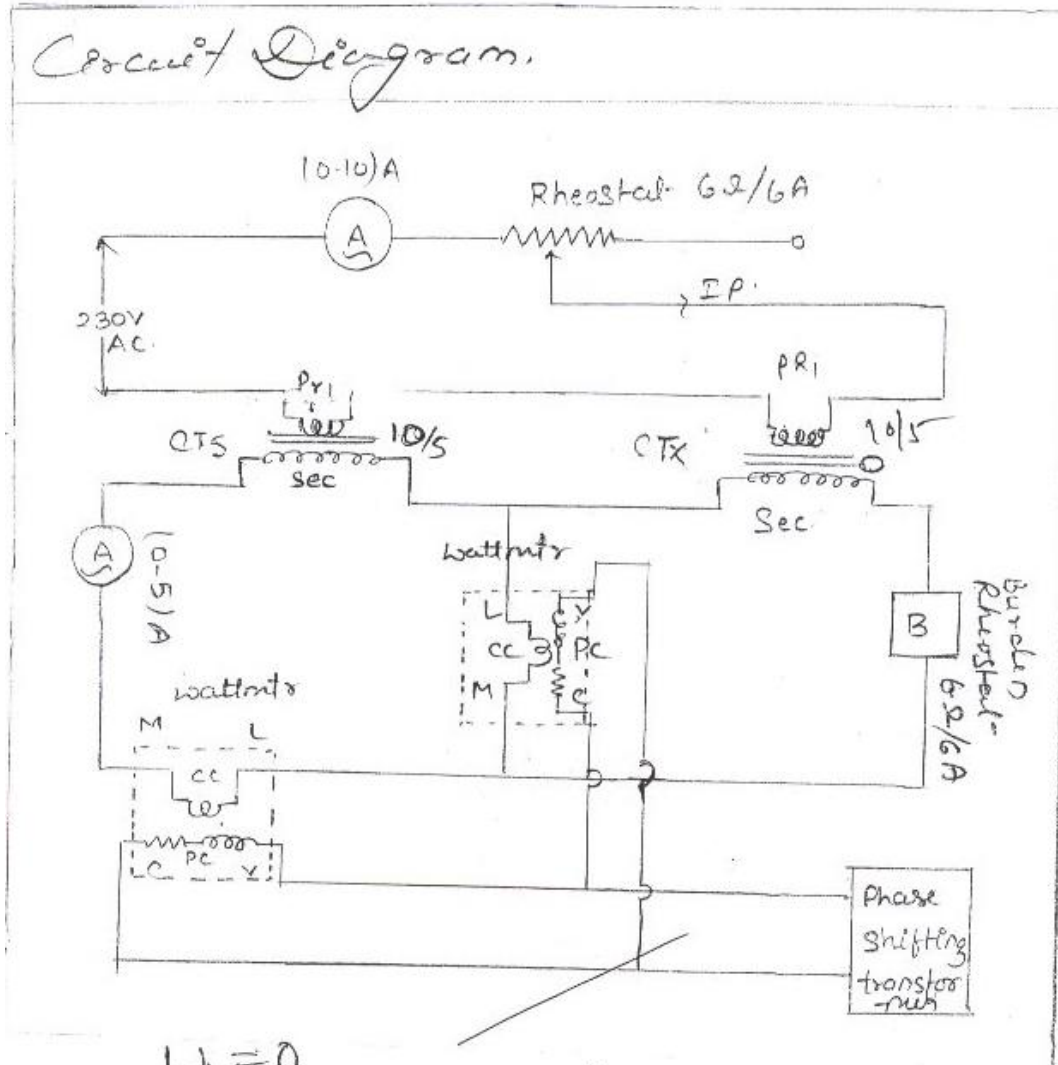

$W_1 = 0$   
 $W_2 \neq 0$

$10^\circ \rightarrow 90^\circ$

$W_{1P}$   
 $W_{2P}$

$$\theta_x = \frac{W_{2P}}{W_{1P} - W_{2P}} + \theta_s$$

**Procedure :**

- The connections are made as per the circuit diagram. The burden is adjusted to have a suitable current in the phase angle is adjusted using the phase shifting transformer will wattmeter W1 reads Zero.
- Reading of the other wattmeter (w2q) is noted.
- A phase shift of 90 is obtained by the phase shifting transformer. The two wattmeter readings W 1p and W2p are then observed.
- The ratio error is calculate ding the formula  $R_x = R_s$
- The phase angle error is calculated using the formula
- The experiment is repeated by varying the curden and setting different values for Iss.
- The average values of Rs and are then obtained.

**Tabular Coloum :**

S. No.	I <sub>ss</sub>	W1q	W2q	W1p	W2p	R <sub>x</sub>	θ <sub>x</sub>

**CALCULATION:****RESULT:**

## 6.6. SCHERING BRIDGE & Anderson Bridge

**AIM :** To determine the capacitance of a capacitor.

### Main features of the bridge :

1.  $R_1$  = three decade resistance dials having range X 10 ohms, X 100 ohms, and X 1000 ohms
2.  $R_2$  = Three more decade resistance of same values as above.
3.  $C_2$  = Two decade capacitance dials having x .001 $\mu$ fd, x .0001  $\mu$ fd
4. C = Four unknown capacitors.
5.  $C_1$  = Standard capacitor. 01  $\mu$ fd. Having negligible dissipation factor (loss free)
6. Inbuilt AC Power supply 1 KHz & Headphone is also provided. 6 interconnection leads of 2mm are also provided for making connection diagram.
7. Single decade resistance dial R having value x 100 ohm.

### Circuit Diagram:

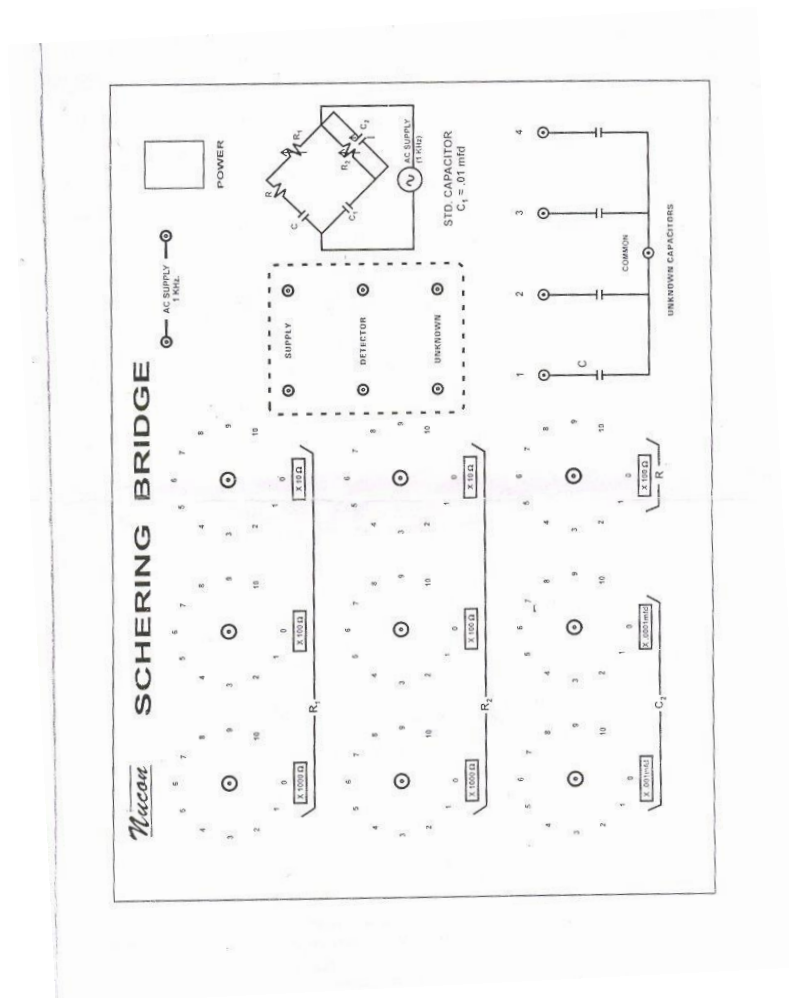

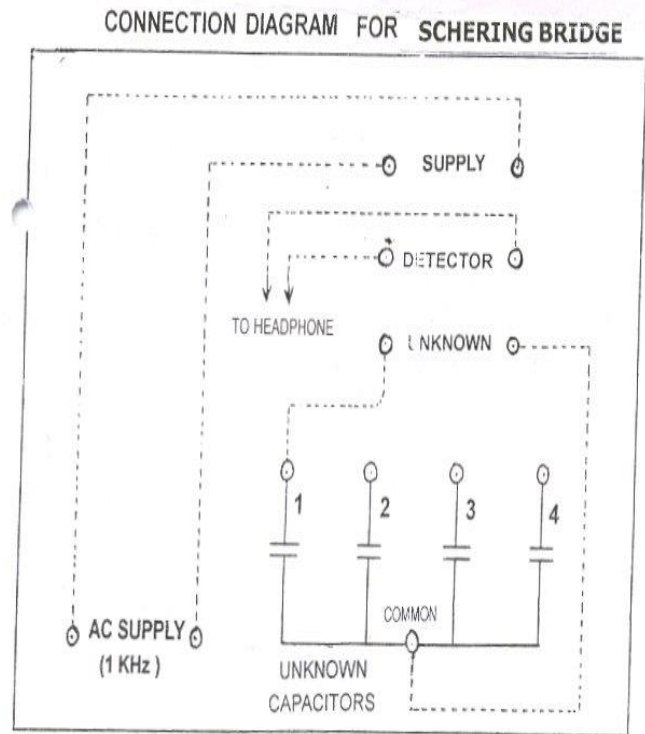
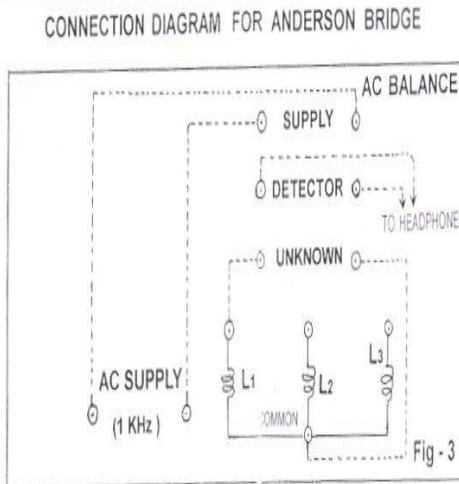
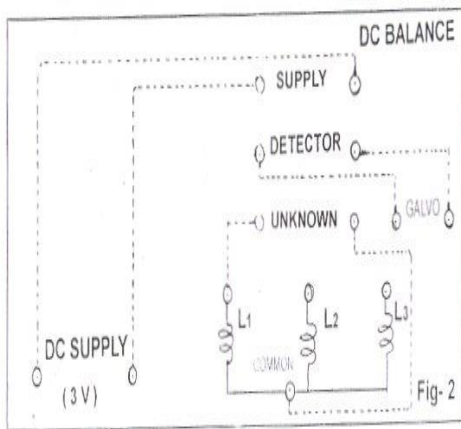
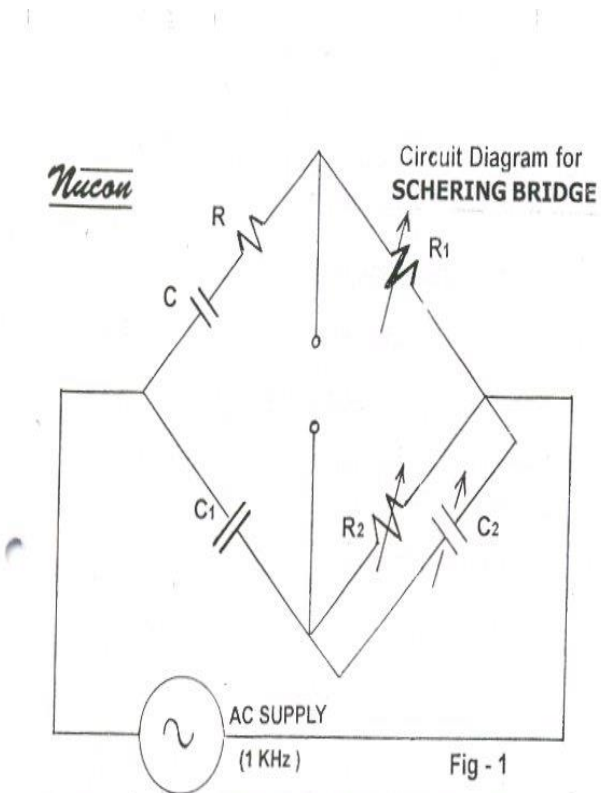
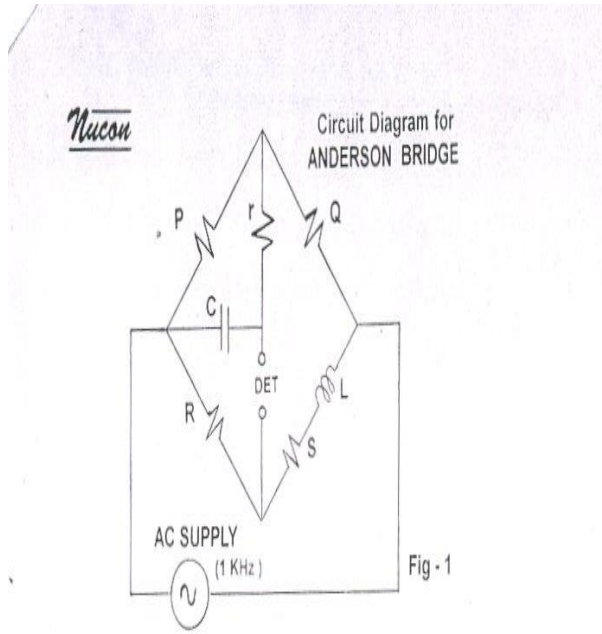

**Procedure :**

Make the connection as shown in fig. 2 using A.C. supply of frequency 1KHz & head phone. Connect one unknown capacitor as shown in connection diagram set the capacitor dial **C<sub>2</sub>** at **zero** position and **R** also at **zero** position. We have made connections internally as per circuit diagram.

Now introduce some resistance from decade resistance dial **R<sub>1</sub>** say **1000 ohms** and **adjust the decade resistance dial R<sub>2</sub>** to minimize the sound in the head phone. With alternate adjustment of decade resistance R<sub>1</sub> and R<sub>2</sub> we can get the minimum sound or no sound in the headphone. Note the value of R<sub>1</sub>, R<sub>2</sub> and C<sub>1</sub>. Calculate the value of unknown capacitor by using formula given below.

$$C = \frac{C_1 \cdot R_1}{R_2}$$

Repeat the experiment with different value of unknown capacitor.

**Note the value of unknown capacitors:**

C = 1 .....	0.01μfd	2. ....	0.02μfd
3 .....	0.01μfd	4 .....	0.02μfd

**Additional Experiment:**

To determine the dissipation factor of a capacitor.

**Dissipation factor:** It is also called power factor of a capacitor and it is a very good test of its quality.

Dissipation factor  $D = CR$

Where  $C = \frac{1}{2\pi f R}$

C = Capacitance of a capacitor

R = Series Resistance of a capacitor representing the loss in the capacitor.



**Procedure:**

Without disturbing the setting of the bridge

(i.e. Null point with  $R_1$  and  $R_2$ )

**Introduce some resistance say 500 ohms** from resistance dial 'R'. There will again be some sound in the headphone. Now

**Adjust the capacitance dial  $C_2$**  to minimise the sound in the using above formula. Repeat the experiment with different value of resistance dial R.

**Observation & Calculations:**

Proceed as described above & note down various readings & Calculate value of Capacitance & Dissipation factor. Match these values with the values of C as mentioned in last page.

**To determine the self Inductance for a coil by Andersonbridge.****Main Features Of the Bridge:**

R ..... Three decade resistance dials having value from 1 ohm to 1 K ohm

R ..... Three decade resistance dials having value for 10 ohm to 10 k Ohm

$C_1$  ..... Two fixed standard capacitors having values 0.1  $\mu\text{fd}$  and 0.2  $\mu\text{fd}$

P and Q ..... Fixed standard values of 1 K ohms each

S ..... Single decade resistance dial having values from 0.1 ohm to 1 OHM

L ..... Three unknown inductance

In built Galvanometer for DC Null point, Head phone & AC supply provided. 6 interconnection leads of 2mm are also provided for making connection diagram.

**Procedure: DC Balance (null point)**

Make the connection as shown in the Fig.2 with DC supply, Galvanometer and one unknown inductance Now adjust the resistance dial R and press the Galvanometer key and get the balance point in the Galvanometer. Use the resistance dial S only for fine balance I the galvanometer and note the value of R.

**AC balance (with headphone):**

Replace the DC supply and AC supply of frequency 1kHz and Galvanometer with headphone as shown in the Fig.3 Set the Standard capacitors C at the position of 0.1  $\mu\text{fd}$  and the adjust the resistance dial r to minimize the sound in the headphone. Note the value of resistance dial r and calculate the value of unknown inductance using below formula.

$$L = CR (Q + 2r)$$

Repeat the experiment with another value of unknown inductance and capacitor  $C_1$  in the same way as mentioned above. Note down the Value of unknown inductances.

1. .... 50mH            2. .... 100mH   3. .... 500mH

**CALCULATION:****RESULT:**

## 6.7. MEASUREMENT OF 3-PHASE REACTIVE POWER USING SINGLE WATTMETER

**AIM :** To measure 3-phase reactive power using single phase wattmeter

### APPARATUS :

1. single phase wattmeter -1 No
2. three phase inductive load

### Theory :

Three phase reactive power can be measured by two wattmeter method which is universally adopted method. The difference between higher readings wattmeter and lower wattmeter readings yields  $V_L I_L \sin \phi$ . So the total 3 reactive power is  $\sqrt{3} V_L I_L \sin \phi$ .

Reactive power in a balance 3- $\phi$  load can also be calculated by using single wattmeter. In this method. The current coil of the wattmeter is connected in any one line and the pressure coils across the other two lines. Let us assume that the current coil is connected in R phase and pressure coil is connected across 'Y' and 'B' phases. Assuming phase sequence RUYB and an inductive load of an angle ' $\phi$ ' the phasor diagram for the circuits is as follows.

Here current through current coil =  $I_R$

Voltage across pressure coil =  $V_{YB}$

The angle between  $V_{YB}$  and  $I_R$  from the phase diagram  $90^\circ - \phi$

Wattmeter reading is  $V_{YB} I_R \cos (90^\circ - \phi)$

$$W = V_{YB} I_R \sin (\phi)$$

In terms of line current and voltage

$$W = V_{YB} I_R \cos (90^\circ - \phi)$$

Terms of line current and voltage

$$W = V_L I_L \sin \phi$$

The total 3- $\phi$  reactive power is  $\sqrt{3} V_L I_L \sin \phi$

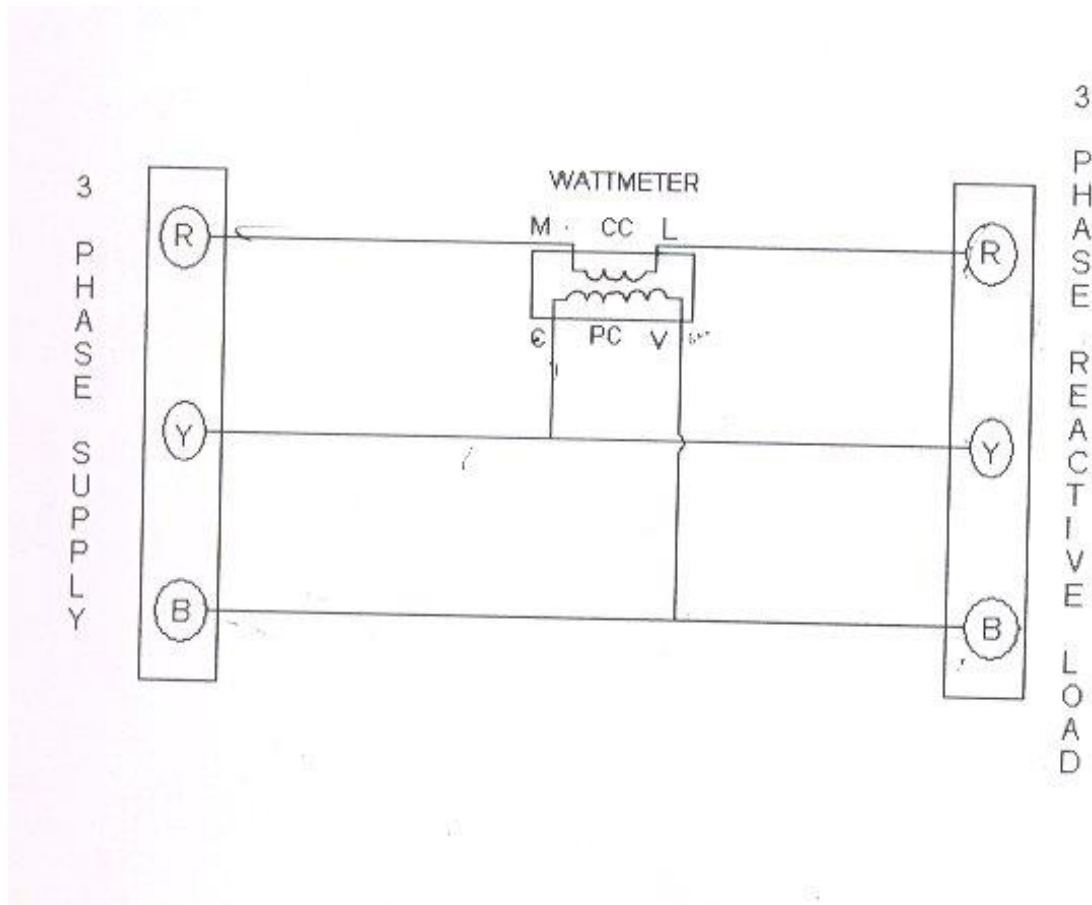
**Circuit Diagram:****Procedure:**

1. Connect the circuit as shown in fig.
2. Switch 'ON' the supply
3. Note down the corresponding there reading and calculate 3- $\phi$  reactive power.
4. Now increase the load of three phase Inductive load steps and note down the corresponding meter readings.
5. Remove the load and switch 'off' the supply.

**Tabular Column:**

<b>3 Phase Load</b>	<b>Wattmeter Reading</b>	<b>3 Phase Reactive Power</b>
<b>1 A</b>		
<b>2 A</b>		
<b>3 A</b>		
<b>4 A</b>		
<b>5 A</b>		

**CALCULATION:****RESULT:**

### 6.8. 3AMMETERS AND 3 VOLTMETERS METHOD

**AIM:** To measure the inductance and power factor of the choke coil using 3 Ammeter and 3 Voltmeter method.

**Apparatus:**

1. Ammeter 0-5A, -3 No's
2. Voltmeters 0-300V -3 No's
3. Resistor
4. Choke coil
5. Auto transformer

**Theory:**

3- Ammeter Method

From the pharos diagram

$$I^2 = I_R^2 + I_L^2 + 2 I_L I_R \cos \phi_L$$

$$\cos \phi_L = \frac{I^2 - I_R^2 - I_L^2}{2 I_L I_R}$$

$$\text{Power drawn the load} = V_L \cos \phi_L$$

$$= I_R R I_L \cos \phi_L$$

$$\text{Since power} = I_R I_L R (I^2 - I_R^2 - I_L^2 / 2 I_L I_R)$$

$$= (I^2 - I_R^2 - I_L^2) R / 2.$$

From the power calculated the inductance of the choke can be calculated

3. Voltmeter Method:

From the pharos diagram

$$V^2 = V_R^2 + V_L^2 + 2 V_R V_L \cos \phi_L$$

$$= \frac{V^2 - V_R^2 - V_L^2}{2 V_R V_L} = \frac{V^2 - V_R^2 - V_L^2}{2 V_R V_L}$$

$$\text{Power drawn by load} = V_L I \cos \phi_L$$

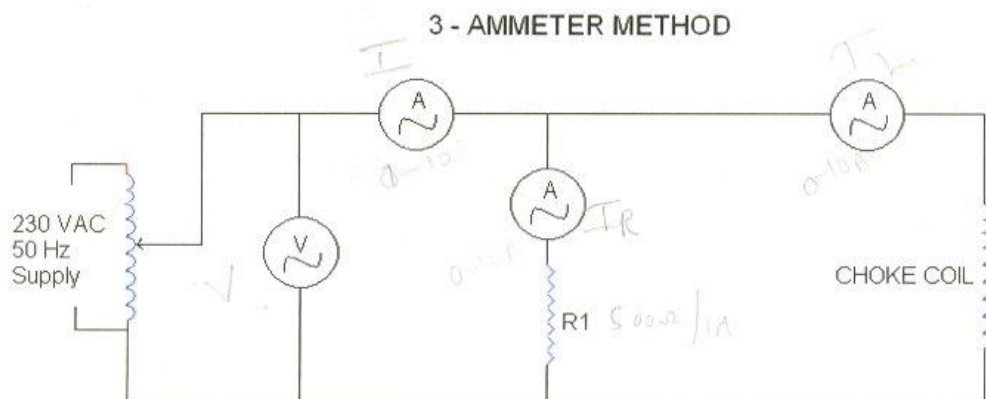
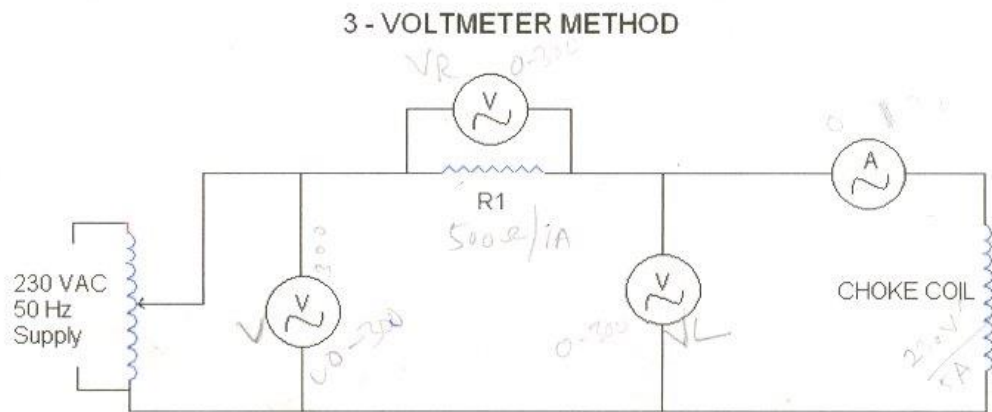
**Circuit diagram:****Procedure:****3 voltmeter Method:**

1. Make connections as per circuit diagram
2. Keep the auto transformer at zero position
3. Switch on the power supply.
4. Increase the voltage gradually from or and note down the I/p voltage  $V_1$  voltage across  $R_1$ ,  $V_1$   $V_2$  and voltage across choke  $V_3$  at difference voltage levels.

**3 Ammeter Methods:**

1. Make connections as per circuit diagram
2. Keep the auto transformer at zero position
3. Increase the voltage gradually from or and note down the current  $I_1, I_2, I_3$  at different steps.

**Tabular Column:****3-ammeter Method**

Voltage	I	IL	IR	Cos $\phi$	PL
25					
50					
75					
100					
125					
150					
175					

$$\cos \phi_L = \frac{I^2 - I_R^2 - I_L^2}{2 I_L I_R}$$

$$\text{Power drawn the load} = V I_L \cos \phi_L$$

$$= I_R R I_L \cos \phi_L$$

$$\text{since Power} = I_R I_L R \left( \frac{I^2 - I_R^2 - I_L^2}{2 I_L I_R} \right)$$

$$= \frac{(I^2 - I_R^2 - I_L^2) R}{2}$$



**3-Voltmeter Method**

Voltage	I	VR	VL	Cos $\phi$	PL
25					
50					
75					
100					
125					
150					

**CALCULATION:****RESULT:**

### 6.9. CALIBRATION OF LPF WATTMETER BY PHANTOM LOADING

**AIM ;** To calibrate LPF wattmeter by phantom loading.

**Apparatus Required:**

1. Voltmeter, 300 V AC
2. Ammeter, 0-10A
3. Variac, Single phase, 10A
4. Rheostat
5. LPF Wattmeter
6. Power Factor Meter

**Theory:**

When the current rating of a meter test is high a test with loading arrangements would involve a considerable waste of power. In order to avoid this “phantom” or “Fictitious” loading is done. Phantom loading consists of supplying the pressure circuit from a circuit from a circuit of required normal voltage, and the current from a separate low voltage supply as the impedance of this circuit very low. With this arrangement the total power supplied for the test is that due to the small pressure coil current at normal voltage, Plus that due to the current circuit current supplied at low voltage. The total power, therefore, required for testing the meter with phantom loading is comparatively very small.

Wattmeter reading = Actual reading

Theoretical reading  $P = V I \cos \phi$

$P =$  Voltmeter reading X Ammeter reading X Power factor reading

Actual Reading – Theoretical Reading

% Error =  $\frac{\text{Actual Reading} - \text{Theoretical Reading}}{\text{Theoretical Reading}} \times 100$

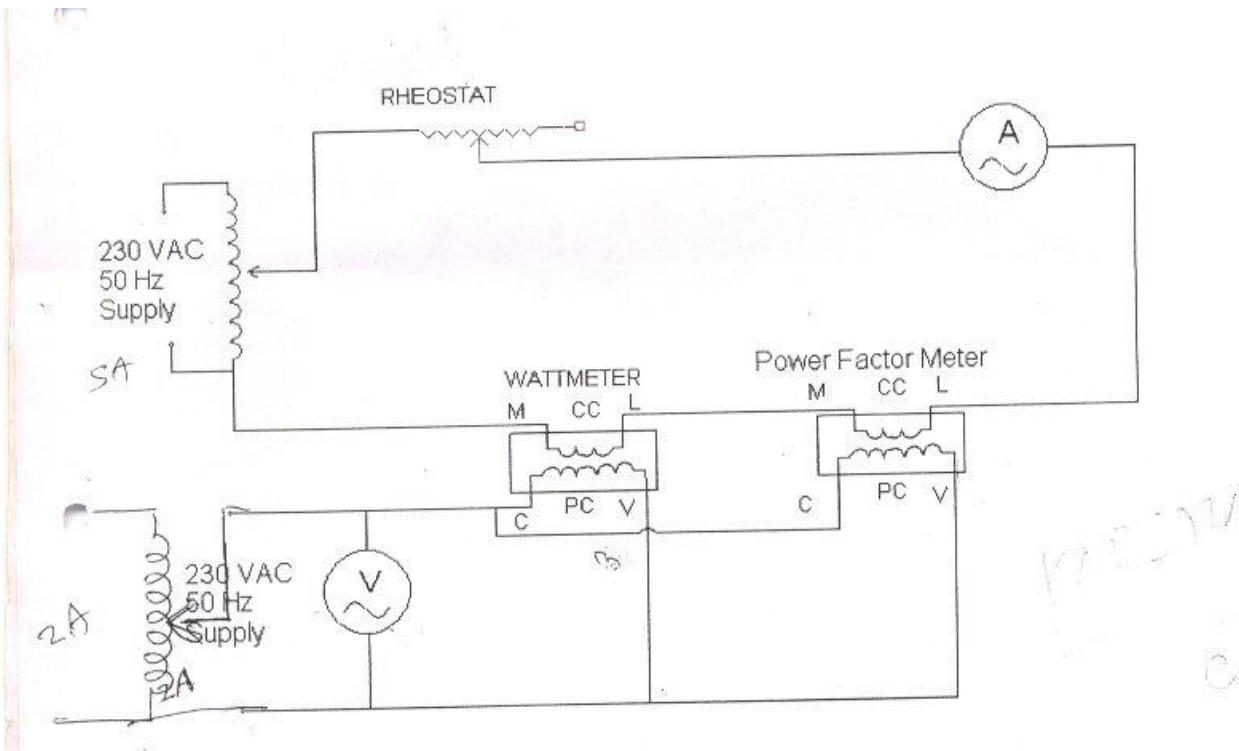
**Circuit Diagram:****Procedure:**

- Keep the Auto transformer at zero position.
- Make connections as per the Circuit diagram shown below.
- Switch on the 230 VAC, 50 Hz, Power Supply.
- Increase the input voltage gradually by rotating the Auto transformer in clockwise direction.
- Adjust the load rheostat so that sufficient current flows in the circuit. Please note that the current should be less than 4A.
- Note down the Voltmeter, Ammeter, Wattmeter and Power factor meter readings for different voltages as per the tabular column
- Find out the percentage error by using above equations.

**Tabular Column:**

S. No.	I in AMPS	V in Volts	Wattmeter Reading	Power Factor	% Error

**CALCULATION:****RESULT:**

### **6.10. MEASUREMENT OF 3 PHASE APOWER WITH SINGLE WATT METER AND 2 NOS OF CURRENT TRANSFORMERS**

**AIM :** To measurement of 3 phase power with single watt meter and 2 nos of current transformers.

**Apparatus:**

1. Wattmeter, LPF, 300V 10A
2. Current transformers – 2 No's

**Theory :**

This method makes of two current transformers of ratio 1:1 to add the phase currents from two phases in the current coil of the wattmeter. The connections are shown in the figure. The potential coil of wattmeter is connected across the some phases.

Voltage across potential coil circuit of wattmer

$$V_{13} = V_1 - V_2 = \sqrt{3} V_p$$

Current through current coil of wattmeter

$$I = I_1 - I_2 = \sqrt{3} I_p$$

Since each of the two vectors is displaced  $30^\circ$  in same direction from the corresponding phase vector so that their phase difference phase is equal to the load power factor angle.

Since power measured by wattmeter

$$\sqrt{3} V_p V_{IP} \cos \phi = 3 V_p I_p \cos \phi$$

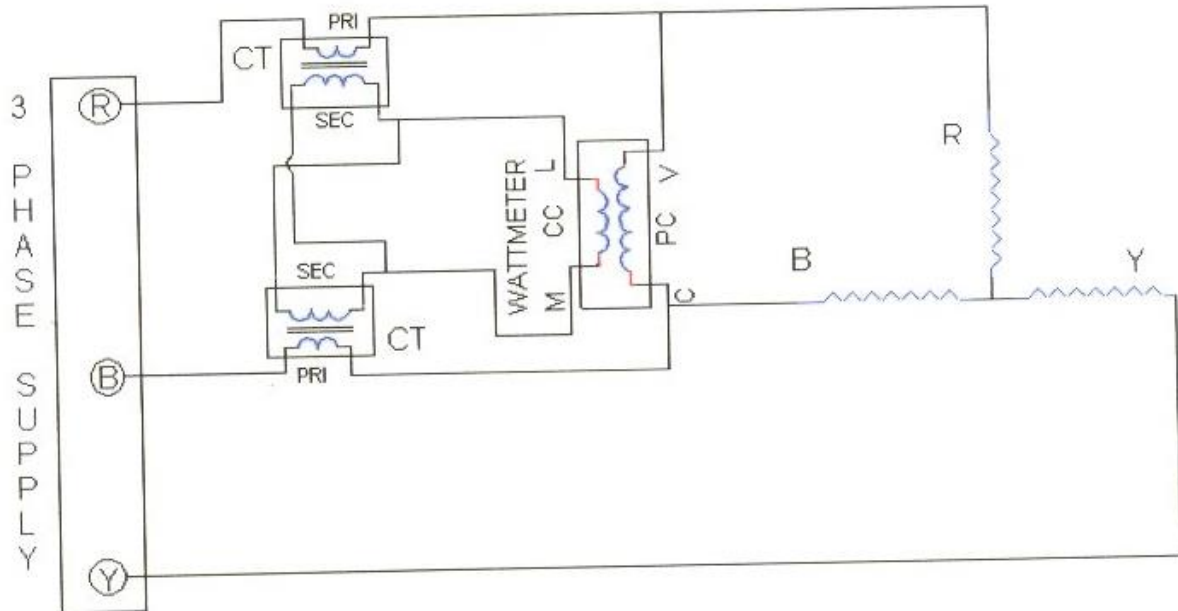
**Circuit Diagram:****Procedure:**

Connect the circuit as shown in fig.

Switch "on" the supply.

Note down the corresponding there reading and calculate 3- $\phi$  power.

Now increase the load of three phase load steps and note down the corresponding meter readings.

Remove the load and switch 'off' the supply.

**OBSERVATION:****CALCULATION:****RESULT:**

### **6.11. MEASUREMENT OF 3-PHASE REACTIVE POWER USING TWO WATTMETER**

**AIM :** The measure 3-phase power using two wattmeter

**Apparatus :**

1. Single phase wattmeter – 2 Nos
2. Three Phase Resistive Load

**Theory:**

Three phase reactive power can be measured by two wattmeter method which is universally adopted method. The difference between higher reading wattmeter and low wattmeter readings yields =  $\sqrt{3} V_L I_L \sin \phi$ . So, the total 3 reactive power is  $\sqrt{3} V_L I_L \sin \phi$ .

Reactive power in a balance 3- $\phi$  load can also be calculated by using single wattmeter. In this method, the current coil of wattmeter is connected in any one line and the pressure coil across the other two lines. Let us assume that the current coil is connected in R phase and pressure coil is connected across 'Y' and 'B' phase. Assuming phases. Assuming phase sequence RYB and an inductive load of an angle the phasor diagram for the circuits is as follows.

Here current through current coil =  $I_R$ .

Voltage across pressure coil =  $V_{YB}$ .

The Phase current lags the corresponding phasor voltage by angle  $\phi$

The current through wattmeter P1 is  $I$  and a voltage across its pressure coil is  $V_L$  leads  $V$  by an angle  $(30-\phi)$

Readings of P1 wattmeter,  $P = V_L I \cos (30-\phi) = \sqrt{3} V_L I \cos (30 + \phi)$

The current through wattmeter P2 is  $I$  and voltages across its pressure coil is  $V_L$  lags  $V$  by an angle  $(30+\phi)$

Readings of P2 wattmeter,  $P = V_L I \cos (30 + \phi) = \sqrt{3} V_L I \cos (30 + \phi)$

Sum of reading of two wattmeters

$P_1 + P_2 = \sqrt{3} V_L I [\cos (30 - \phi) - \cos (30 + \phi)]$

$3V_L I \cos \phi$  This is total power consumed by load  $p=P_1 + P_2$

Difference of readings of two wattmeters

$$P_1 - P_2 = \sqrt{3} VI [\cos (30-\phi) - \cos (30 + \phi)]$$

$$= \sqrt{3} VI \sin \phi$$

$$\frac{P_1 - P_2}{P_1 + P_2} = \frac{\sqrt{3}VI \sin \phi}{\sqrt{3}VICos\phi} = \frac{\tan \phi}{\sqrt{3}} \text{ or } \phi = \tan^{-1} \sqrt{3} \frac{P_1 - P_2}{P_1 + P_2}$$

$$\text{Power factor } \cos \phi = \cos \tan^{-1} \sqrt{3} \frac{P_1 - P_2}{P_1 + P_2}$$

Current through the current coil = I

Voltage across the pressured coil = V

$$Q = 3VI \sin \phi = -\sqrt{3} * \text{readings of wattmeter}$$

Phase angle  $\phi = \tan^{-1} Q/P$

**Circuit Diagram:**

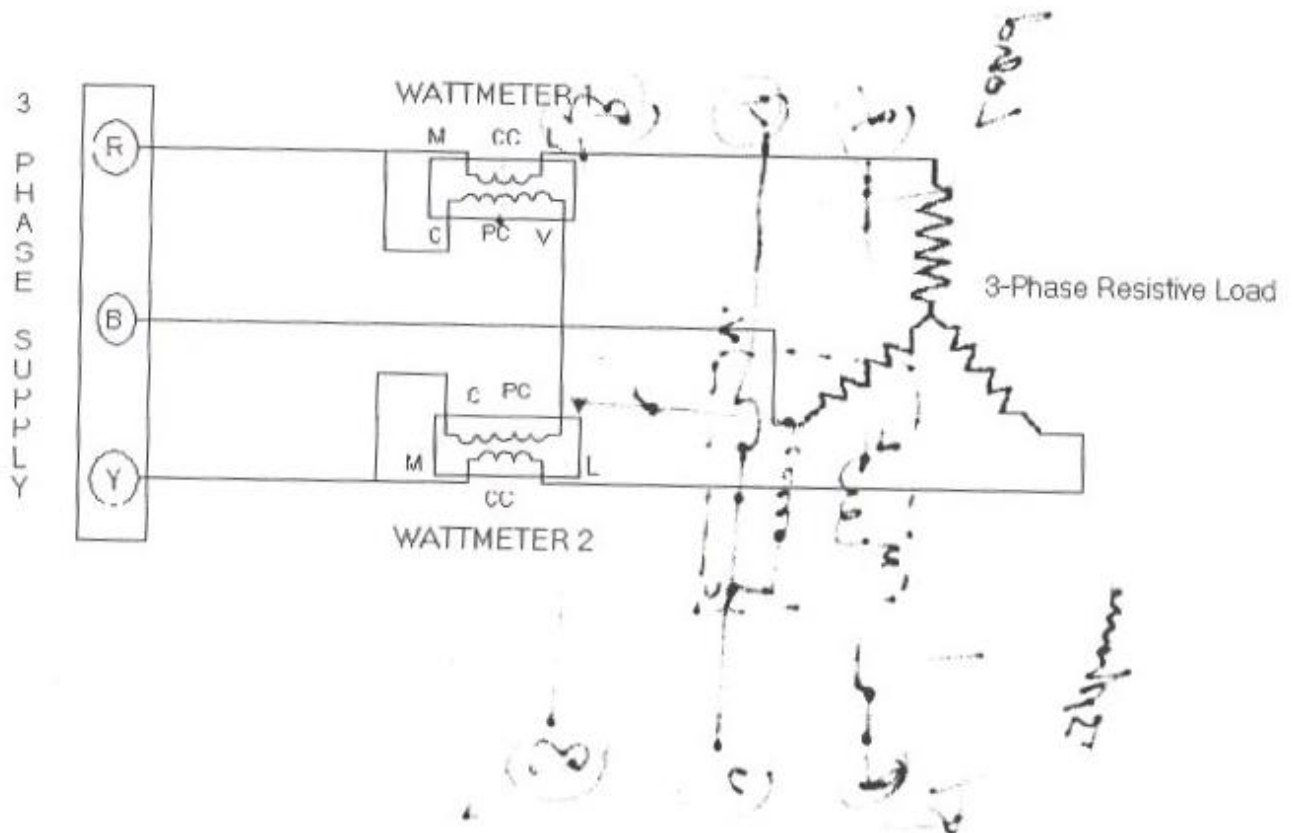



**Procedure:**

1. connect the circuit as shown in fig.
2. Switch 'ON' the supply.
3. Note down the corresponding there reading and calculate 3- $\phi$  reactive power.
4. Now increase the load of three phase inductive load steps and note down the corresponding meter readings.
5. Remove the load and switching 'off' the supply.

**Tabular Column:**

<b>3 Phase Resistive Load</b>	<b>Wattmeter Reading</b>	<b>3 Phase Reactive Power</b>

**CALCULATION:****RESULT:**

## 6.12 LVDT AND CAPACITANCE PICKUP-CHARACTERISTICS AND CALIBRATION

### AIM:

To measure the displacement using linear variable differential transformer.

### APPARATUS:.

SlNo.	Name	Type	Range	Qty.
1	LVDT trainer kit			
2	LVDT			
3	Digital multimeter			

### THEORY:

Linear variable differential transformer LVDT is a transducer. Basically it is passive inductive transformer similar to a potential transformer. LVDT consists of three windings, one primary and two secondaries of equal turns. Primary is wound centrally between two secondaries. All three windings are wound on a hollow tubular former through which magnetic core slides. Core affects magnetic coupling between primary and the secondaries while primary is connected to an AC signal. Normal / null position of core causes equal induced voltage in both the secondaries. Hence the total difference voltage of both the secondaries becomes zero. Any deviation in core position from its null position induces unequal voltage from both secondaries and hence the difference signal of it is a non zero quantity, this non zero quantity varies with core position. Ideally displacement versus change in difference signal should be linear. When  $E_{S1} = E_{S2}$  (core at null position or central position)  $E_{diff} = 0$  When core is moved left

$E_{S1} > E_{S2}$  &

$E_{diff}$  ( $E_{S1} - E_{S2}$ ) is in phase with  $E_{S1}$

When core is moved right  $E_{S1} < E_{S2}$

$E_{diff}$  ( $E_{S1} - E_{S2}$ ) is in phase with  $E_{S2}$ .

Amount of  $E_{diff}$ . is proportional to the displacement of core. Phase angle of the output voltage decides the direction of core from its normal null position. Electronic circuit can be used to

recover appreciable difference signal from LVDT. LVDT offers linearity in the output for certain Range of displacement. Change in its output voltage is stepless and resolution depends on test equipment. Higher magnitude output is possible. LVDT can tolerate high degree of vibration and shocks and hence more rugged. Repeat accuracy is better due to low hysteresis. Disadvantages of LVDT are its sensitivity towards stray magnetic field (magnetic shielding is possible), large displacement is required for appreciable differential output.

### CIRCUIT DIAGRAM:

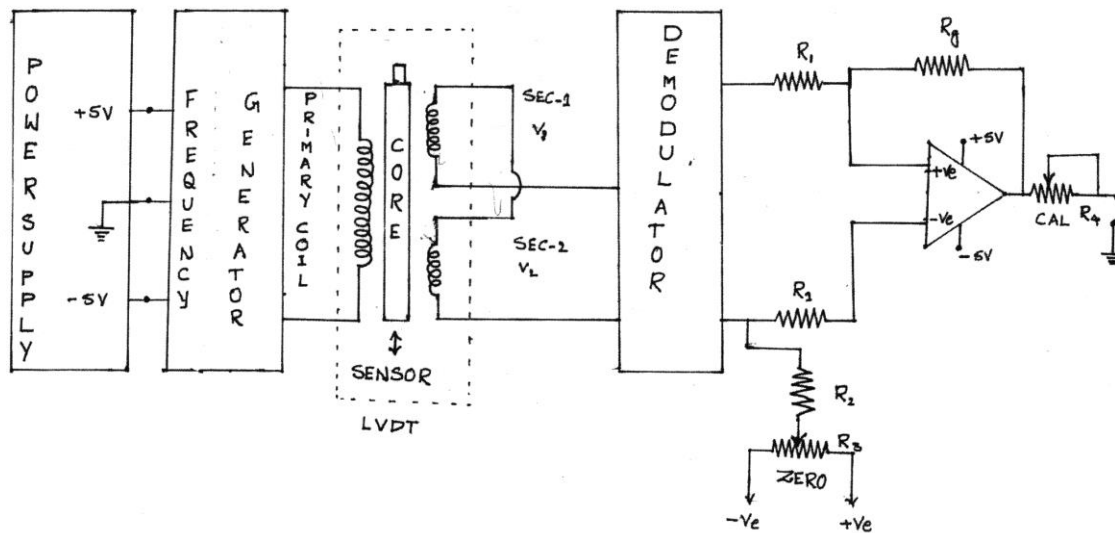

### PROCEDURE:

1. Connections are made as per the circuit diagram.
2. Switch on the supply keep the instrument in ON position for 10 minutes for initial warm up.
3. Rotate the micrometer core till it reads 20.0 mm and adjust the CAL potentiometer to display 10.0 mm on the LVDT trainer kit.
4. Rotate the micrometer core till it reads 10.0 mm and adjust the zero potentiometer to display 20.0 mm on the LVDT trainer kit.
5. Rotate back the micrometer core to read 20.0 mm and adjust once again the CAL potentiometer till the LVDT trainer kit display reads 10.0 mm. Now the instrument is calibrated for 10mm range.

6. Rotate the core of micrometer in steps of 2 mm and tabulate the readings of micrometer, LVDT trainer kit display and multimeter reading.

**Observations:**

S. No.	Micro Meter reading in mm	Output voltage

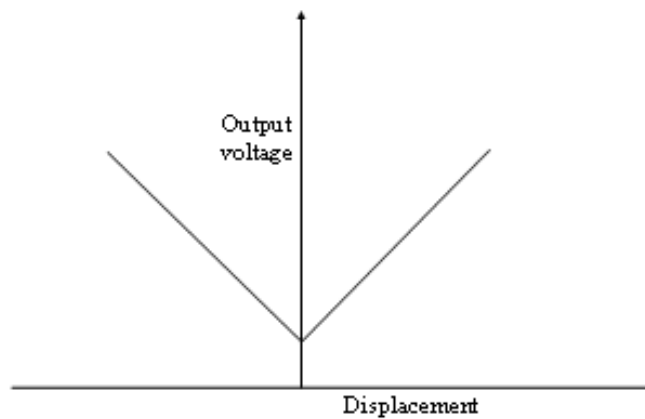
**GRAPH:**

**RESULT:** Displacement is measured using linear variable differential transformer and graphs of indicated displacement Vs actual displacement, %Error Vs actual displacement and output voltage Vs actual displacement.

### 6.13 MEASUREMENT OF IRON LOSS IN A BAR SPECIMEN USING A CRO AND USING A WATTMETER

#### AIM:

To measure the iron losses in strip (sheet) material using Lloyd - Fisher Square.

#### APPARATUS:

Sl.No.	Name	Type	Range	Qty.
1	Ammeter			
2	Voltmeter			
3	Wattmeter			
4	Lloyd fisher square (specimen)			
5	1- $\phi$ variac			

#### THEORY:

The voltage across the secondary i.e. voltmeter reading given the rms value of the induced voltage.

$$E = 4.44 f N_2 \Phi_m$$

$N_2$  = No. of turn of the secondary winding.

$$\Phi_m = \frac{f N_1 A_c}{l_m}$$

$E$ (apparent value)

$A_s$  = area of specimen; m<sup>2</sup>

$$B_m = B_m1 - \mu_0 H_m$$

$A_c$  = Cross sectional area of coil; m<sup>2</sup>

$H_m$  = Magnetizing force corresponding to maximum flux density; A/m. (obtained from B.H. curve of specimen)

Wattmeter reading = iron loss in the specimen + Copper loss in the secondary

Lloyd fisher-square is most commonly used for measurement of iron loss in strip material. The strip

material to be tested is assembled as a closed magnetic circuit in the form of a square, called magnetic

square. The strips used are usually 0.25m long & 50 to 60mm wide, and ferromagnetic material.

#### Circuit diagram:

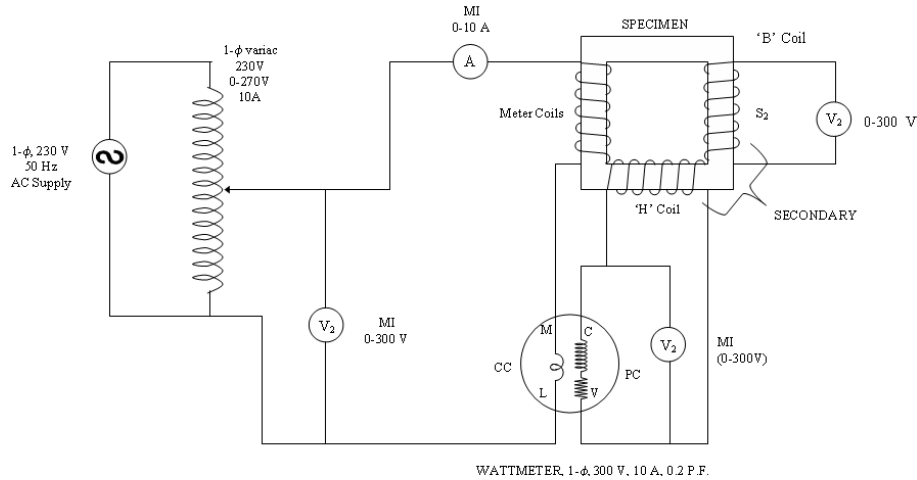

**PROCEDURE:**

1. Connect the circuit as shown in figure.
2. Adjust the voltage applied to the primary till the ammeter reads gives the required value of  $B_m$ .
3. Observe the wattmeter and voltmeter reading.
4. Reduce the current insteps of 0.5A and note down the readings.
5. Switch OFF the circuit and calculate iron loss.

**OBSERVATIONS :**

Ammeter Reading	Wattmeter Reading	Voltmeter Reading		
		V <sub>1</sub>	V <sub>2</sub>	V <sub>3</sub>

**CALCULATIONS:**

$P =$  Wattmeter reading  
 $P_i =$  iron loss =  $r_p r_c$

**Result:** Iron loss are calculated in a bar specimen by using Lloyd fisher square method, by conducting the experiment.

## **7. Content beyond syllabus:**

1: MAXWELL BRIDGE

2: CARY FOSTER BRIDGE

3: OVENS BRIDGE

4: HAYS BRIDGE

5: TESTING OF P.F METER

## 8 Sample Viva Voce Questions.

### EXP:1:

1. What is an energy meter?
2. What are the types of energy meter?
3. Which type of energy meters are used in dc circuits?
4. Energy meter is an \_\_\_\_\_ (i) integrating instrument (ii) indicating instrument
5. Can the measured percentage error be negative?
6. What do you mean by 'torque adjustment'?
7. What is operating torque?
8. Define braking torque?
9. When does the disc on the spindle rotate with a constant speed?

### EXP:2

1. State the widely used power factor meter?
2. What do you mean by true power? State the formula?
3. Is there any limit in mechanism to develop the controlling torque in dynamometer pf meter?
4. The angular displacement of the coil is proportional to system phase angle. State True/False.
5. What are the two different types of power factor meter?
6. What is the position of the pointer when no current flows in the circuit?
7. Torque acting on the coil P1 is directly proportional to \_\_\_\_\_
8. Torque acting on coil P2 is directly proportional to \_\_\_\_\_
9. The condition for the spindle to be in equilibrium?
10. The angular displacement of the coils is equal to \_\_\_\_\_

### EXP:3

1. What do you mean by a potentiometer?
2. What are the types of potentiometer?
3. What is the working principle of a potentiometer?
4. What is standardization of potentiometer?
5. What is the purpose of connecting a standard battery in the circuit?
6. Application of dc potentiometer?
7. What do you mean by calibration curve of the ammeter?
8. What do you mean by a volt-ratio box?
9. What are the types of AC potentiometer?
10. What are the practical applications of ac potentiometer?



**EXP:4**

1. Classify resistance?
2. Examples of high resistance?
3. What are the methods employed in measuring low resistances?
4. Which is the most accurate method to measure the low resistances? State the reason?
5. Kelvin double bridge is a modified version of ?
6. What is the main problem in measuring low resistances?
7. How do we measure high resistances?
8. Practical methods to measure earth resistance?
9. What are the quantities that are measured by ac bridges?

**EXP:5**

- 1 How types of Silsbee's methods ? And what are those ?
- 2 Silsbee's methods----- method
- 3 What is Burden of transformer?
- 4 Define (C.T&P.T) A. Transformation ratio  
B. Turns ratio  
C .Nominal ratio  
D .RCF
- 5 Comparison between C.T & P.T

**EXP:6**

1. What do you mean by high voltage Schering Bridge?
2. State some of the errors that occur in bridge measurements?
3. Anderson Bridge is a modified version of \_\_\_\_\_
4. In Anderson Bridge the self inductance is measured in comparison with \_\_\_\_\_
5. What are the resistors need to be adjusted to get the balance
6. At what condition the galvanometer detector will be replaced by the head phone.
7. Schering bridge is used for the measurement of \_\_\_\_\_
8. What is meant by loss angle ?
9. Why we are doing electrostatic shielding for high voltage Schering bridge?
10. What are the elements need to be adjusted to obtain balance in Schering bridge?

**EXP:7**

1. What do you mean by high voltage Schering Bridge?
2. State some of the errors that occur in bridge measurements?
3. Anderson Bridge is a modified version of \_\_\_\_\_
4. In Anderson Bridge the self inductance is measured in comparison with \_\_\_\_\_
5. What are the resistors need to be adjusted to get the balance
6. At what condition the galvanometer detector will be replaced by the head phone.
7. Schering bridge is used for the measurement of \_\_\_\_\_
8. What is meant by loss angle ?
9. Why we are doing electrostatic shielding for high voltage Schering bridge?
10. What are the elements need to be adjusted to obtain balance in Schering bridge?

**EXP:8**

1. How do you measure power ?
2. State the difference between wattmeter and an energy meter?
3. Types of wattmeters?
4. Which types of wattmeter is widely used?
5. How is the controlling torque obtained?
6. What are the errors in dynamometer type wattmeters? State a few.
7. How many wattmeters do we require to measure 3-phase power?
8. What is reactive power ? State the formula.
9. How many wattmeters are required to measure 3-phase reactive power?
10. How do we minimize the errors due to eddy currents in wattmeters?

**EXP:9**

1. What are the choke coil parameters?
2. What is the function of choke?
3. What are the methods are there to find choke coil parameters?
4. What are the methods are there to find choke coil parameters?
5. Which method is very important for finding the choke coil parameters?

**EXP:10**

1. What is meant by correction factor ?
2. The load current in LPF wattmeter is high / low ?
3. Why are the LPF wattmeter designed to have a smaller controlling torque ?
4. What is the need of introducing compensating coil?
5. State a few errors in dynamometer wattmeter?
6. Applications of LPF wattmeter?
7. Why more operating torque is produced in LPF wattmeter?
8. Why the controlling torque in an LPF wattmeter is less?
9. What are the different methods used for measurement for 3-phase power?

**EXP:11**

1. What is Burden of transformer?
2. Define (C.T&P.T) A. Transformation ratio  
B. Turns ratio  
C .Nominal ratio  
D .RCF
- 3 Why C.T secondary should not be opened?
- 4 Comparison between C.T & P.T

**Exp:12=**

1. What is LVDT?
2. What is transducer?
3. How many transducers are there?
4. How many windings the transformer in LVDT have in its construction?
5. How the secondaries are connected in the transformer of LVDT?

**Exp:13**

1. What are the methods of measuring iron losses?
2. What are the two types of squares used to measure iron losses?
3. Which square is preferred to measure iron losses?
4. How the strips are located in Epstein square and Lloyd-Fisher square?
5. What are iron losses?
6. What are the types of iron losses?
7. How the hysteresis loss is minimized?
8. How the eddy current loss is minimized?
9. Define form factor?

**9. Sample Question paper of the lab external**

- 1** Calibratr And Test the Single Phase Energy Meter
- 2** Calibrate the Dynamometer Type Power Factor Meter
- 3** Calibrate the PMMC ammeter and PMMC voltmeter
- 4** Measure the resistance and Determination of Tolerance
- 5** TEST the CURRENT TRANSFORMERS
- 6** Calculate the unknown inductance and capacitance using Anderson bridge. & shearing bridge
- 7** Measure the 3 Phase reactive power with single – phase wattmeter
- 8** Measure the parameters of a choke coil using 3 voltmeter and 3 ammeter methods
- 9** Calibrate the LPF wattmeter – by Phantom testing
- 10** Measure the 3 phase power with single watt meter and 2 No's of C.T.
- 11** Measure the 3-phase Reactive Power using two wattmeters.
- 12** MEASURE the IRON LOSS IN A BAR SPECIMEN USING A CRO AND USING A WATTMETER

**10. Applications of the laboratory :**

One of the major goals of this lab is to familiarize the student with the proper equipment and techniques for making electrical measurements. Some understanding of the lab instruments is necessary to avoid personal or equipment damage. By understanding the device's purpose and following a few simple rules, costly mistakes can be avoided.

## 11. Precautions to be taken while conducting the lab

- Power must be switched-OFF while making any connections.
- Do not come in contact with live supply.
- Power should always be in switch-OFF condition, EXCEPT while you are taking readings.
- The Circuit diagram should be approved by the faculty before making connections.
- Circuit connections should be checked & approved by the faculty before switching on the power.
- Keep your Experimental Set-up neat and tidy.
- Check the polarities of meters and supplies while making connections.
- Always connect the voltmeter after making all other connections.
- Check the Fuse and it's ratify.
- Use right color and gauge of the fuse.
- All terminations should be firm and no exposed wire.
- Do not use joints for connection wire.
- While making 3-phase motor ON, check its current rating from motor name plate details and adjust its rated current setting on MPCB(Motor Protection Circuit Breaker) by taking approval of the faculty.
- Before switch-ON the AC or DC motor, verify that the Belt load is unloaded.
- Before switch-ON the DC Motor-Generator set ON, verify that the DC motor field resistance should be kept in minimum position. Where as the DC generator / AC generator field resistance should be kept in Maximum position.
- Avoid loose connections. Loose connections leads to heavy sparking & damage for the equipments as well as danger for the human life.
- Before starting the AC motor/Transformer see that their variacs or Dimmerstats always kept in zero position.
- For making perfect DC experiment connections & avoiding confusions follow color coding connections strictly. Red colour wires should be used for positive connections while black color wires to be used for Negative connections.

- After making DPST switch/ICTPN switch-OFF see that the switch is switched-OFF Perfectly or not. Open the switch door & see the inside switch contacts are in open. If in-contact inform to faculty for corrective action.
- For safety protection always give connections through MCB (Miniature circuit breaker) while performing the experiments.

### **SAFETY – II**

1. The voltage employed in electrical lab are sufficiently high to endanger human life.
2. Compulsorily wear shoes.
3. Don't use metal jewelers on hands.
4. Do not wear loose dress

Don't switch on main power unless the faculty gives the permission4 Do not start the series motor without load.

- 5 Keep the armature rheostat in maximum position.

## 12. Code of Conduct

- ❖ All students must observe the Dress Code while in the laboratory.
- ❖ Sandals or open-toed shoes are NOT allowed.
- ❖ Foods, drinks and smoking are NOT allowed.
- ❖ All bags must be left at the indicated place.
- ❖ The lab timetable must be strictly followed.
- ❖ Be PUNCTUAL for your laboratory session.
- ❖ Experiment must be completed within the given time.
- ❖ Noise must be kept to a minimum.
- ❖ Workspace must be kept clean and tidy at all time.
- ❖ Handle all apparatus with care.
- ❖ All students are liable for any damage to equipment due to their own negligence.
- ❖ All equipment, apparatus, tools and components must be RETURNED to their original place after use.
- ❖ Students are strictly PROHIBITED from taking out any items from the laboratory.
- ❖ Students are NOT allowed to work alone in the laboratory without the Lab Supervisor
- ❖ Report immediately to the Lab Supervisor if any injury occurred.
- ❖ Report immediately to the Lab Supervisor any damages to equipment.

### **Before leaving the lab**

- ❖ Place the stools under the lab bench.
- ❖ Turn off the power to all instruments.
- ❖ Turn off the main power switch to the lab bench.
- ❖ Please check the laboratory notice board regularly for updates



**13. Graphs if any.**